



The pages in this document have been extracted from a larger document and as such any page numbers are relevant only to the original document.

HENGSTLER

Rotary Encoder Solutions Limited
Dutton Road
Redwither Business Park
Wrexham
LL13 9UL

tel: +44(0) 1978 664722
fax: +44(0) 1978 664733
email: sales@rotaryencodersolutions.com
web: www.rotaryencodersolutions.com

Rotary Encoder Solutions is part of the Industrial Encoders Direct Ltd. Group of Companies and is trading as Industrial Encoders Direct Ltd

The information shown in this document is for reference purposes only and forms no contractual obligation. Any detail in this document may be changed without prior notice. No liability is accepted for any information contained in this document.



HENGSTLER

Incremental Shaft Encoders Type RI 59

Stainless steel encoders



- Stainless steel encoder with high protection class
- High corrosion resistance
- Use in the area of food production or if sea-water proof is required
- Application e.g.:
 - packing machines
 - bottling machines
 - washing plants
 - mixers
 - cranes
 - hoists
 - marine outfitters

NUMBER OF PULSES

1 / 2 / 3 / 4 / 5 / 10 / 15 / 20 / 25 / 30 / 35 / 40 / 45 / 50 / 60 / 64 / 70 / 72 / 80 / **100** / 125 / 128 / 144 / 150 / 180 / 200 / 230 / **250** / 256 / 300 / 314 / 350 / 360 / 375 / 400 / 460 / 480 / **500** / 512 / 600 / 625 / 635 / 720 / 750 / 900 / **1000** / **1024** / 1200 / **1250** / 1500 / 1600 / 1800 / 2000 / 2048 / **2500** / 3000 / 3480 / **3600** / 3750 / 3968 / 4000 / **4096** / 4800 / **5000** / 5400 / 6000 / 7200 / 7680 / 8000 / 8192 / 9000 / 10000

Other number of pulses on request

Preferably available versions are printed in bold type.

TECHNICAL DATA mechanical

Shaft diameter	9.52 mm / 10 mm
Absolute max. shaft load	radial 60 N / axial 40 N
Absolute max. speed	10 000 min ⁻¹
Torque	≤ 1 Ncm
Moment of inertia	approx. 20 gcm ²
Protection class (EN 60529)	Housing IP67, bearings IP67
Operating temperature	-10 ... +70 °C
Storage temperature	-25 ... +85 °C
Vibration resistance (IEC 68-2-6)	100 m/s ² (10 ... 2000 Hz)
Shock resistance (IEC 68-2-27)	1000 m/s ² (6 ms)
Connection	1.5 m cable ¹ radial or axial
Housing	Stainless steel Ø 58 mm
Flange	Q=Square flange 63.5 x 63.5 mm
Weight approx.	620 g

¹ Other cable length on request

TECHNICAL DATA electrical

General design	as per DIN VDE 0160, protection class III, Contamination level 2, over voltage level II	
Supply voltage (SELV)	with RS 422 + Sense (T):	DC 5 V ± 10 %
	with RS 422 + Alarm (R):	DC 5 V ± 10 % oder DC 10 - 30 V ²
	with push-pull (K, I):	DC 10 - 30 V ²
Max. current w/o load	40 mA (DC 5 V), 60 mA (DC 10 V), 30 mA (DC 24 V)	
Standard output versions ³	RS 422 (R):	A, B, N, \overline{A} , \overline{B} , \overline{N} , \overline{Alarm}
	RS 422 (T):	A, B, N, \overline{A} , \overline{B} , \overline{N} , Sense
	push-pull (K):	A, B, N, \overline{Alarm}
	push-pull complementary (I):	A, B, N, \overline{A} , \overline{B} , \overline{N} , \overline{Alarm}

² Pole protection with supply voltage DC 10 - 30 V

³ Output description and technical data see chapter "Technical basics"

Incremental Shaft Encoders Type RI 59

Stainless steel encoders

DIMENSIONAL DRAWINGS

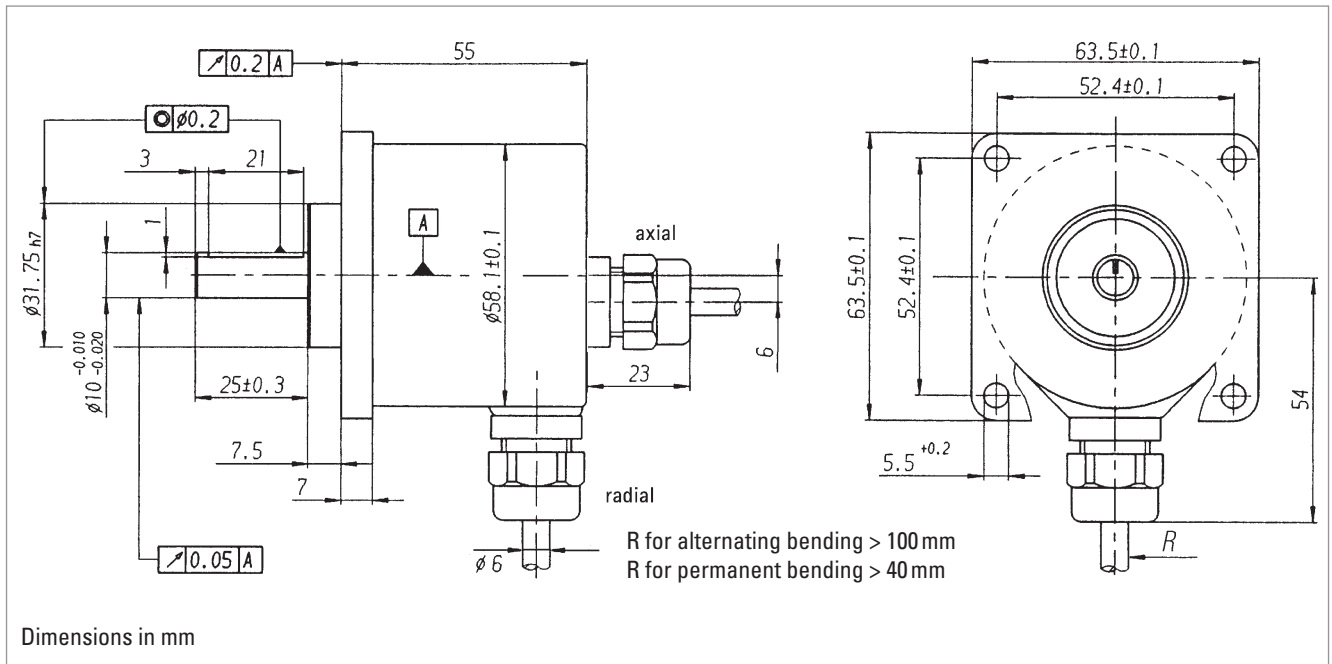

PIN ASSIGNMENT

Connecting cable		Output	
Colour	Lead \varnothing mm ²	RS 422 T and R	push-pull K and I
red	0.5	DC 5/10 - 30 V	DC 10 - 30 V
red/yellow	0.14	Sense V_{CC}	Sense V_{CC}
white	0.14	Channel A	Channel A
white/brown	0.14	Channel \bar{A}	Channel \bar{A} ¹
green	0.14	Channel B	Channel B
green/brown	0.14	Channel \bar{B}	Channel \bar{B} ¹
yellow	0.14	Channel N	Channel N
yellow/brown	0.14	Channel \bar{N}	Channel \bar{N} ¹
black	0.5	GND	GND
black/yellow	0.14	Alarm /Sense GND ²	Alarm
screen ³		screen ³	screen ³

¹ only push-pull complementary (I)

² depending on ordering code

³ connected with encoder housing

ORDERING INFORMATION

Type	Model	Number of pulses	Supply voltage	Flange, Protection, Shaft	Output	Connection
RI59-	0 Standard	1 ... 10 000	A DC 5 V E DC 10 - 30 V	Q.7A Square 63.5 x 63.5, IP67, 10 mm x 25 Q.7B Square 63.5 x 63.5, IP67, 9.52 mm x 25	T RS 422 + Sense K push-pull short circuit proof I push-pull complementary R RS 422 + Alarm	A PVC cable axial B PVC cable radial



HENGSTLER

D Inkrementeller Drehgeber
RI 58-O / RI 58-T / RI 59
Installationsanleitung

GB Incremental Encoders
RI 58-O / RI 58-T / RI 59
Installation instructions

F Codeur incrémental
RI 58-O / RI 58-T / RI 59
Instructions d'installation

I Trasduttori incrementali
RI 58-O / RI 58-T / RI 59
Istruzioni di installazione

E Transmisores giratorios incrementales
RI 58-O / RI 58-T / RI 59
Instrucciones de instalación

Art. No.: 2 522 479
Edition.: 3 290906 MM

HENGSTLER

Hotline
+49 (0) 74 24 / 89 - 0

HENGSTLER GmbH
Uhlandstr. 49
D-78554 Aldingen
http://www.hengstler.de
e-mail: info@hengstler.de

GB 2. Safety

Authorised persons
The encoder should only be assembled and dismantled by a qualified electrician, as the unit contains sensitive electronic circuits.

Risk of injury due to rotating shafts
Hair and items of clothing may become caught up in rotating shafts.
→ Prior to commencing all works, disconnect all power supplies and ensure that the working environment is safe!

Risk of destruction due to static electricity
The CMOS modules contained in the encoder are very sensitive to high voltages such as can arise due to friction of the clothing.
→ Do not touch plug contacts or electronic components!

Risk of destruction due to mechanical overload
Rigid mounting will give rise to constraining forces which will permanently overload the bearings.
→ Never restrict the freedom of movement of the encoder! Use only the enclosed sheet steel springs or a suitable coupling to secure the unit!

Risk of destruction due to mechanical shock
Violent shocks, e.g. due to hammer blows, can lead to the destruction of the optical sensing system and the ball bearings.
→ Never use force! Assembly is simple provided that correct procedure is followed.

Risk of destruction due to overloading
→ The unit may only be operated within the limits specified in the technical data.

Fields of application: industrial processes and controls.
Over voltage at the connecting terminals must be limited to over voltage-class-II values (SELV).
The connecting cable is not for dragline mounting, only for fix mounting.
This encoder is a supply part destined for mounting to an appliance (motor, machine). It is not provided for customer sale.
Manufacturers integrating this encoder to their facilities are responsible as well for compliance with CE guidelines as for the CE mark.

F 2. Sécurité

Personnel autorisé
Du fait que le codeur renferme des circuits électroniques sensibles, seul le personnel compétent est autorisé à monter ou démonter le codeur.

Mise en garde contre les arbres en rotation
Les cheveux et les vêtements peuvent être happés par les arbres en rotation.
→ Prière de sécuriser l'environnement de travail avant de mettre les machines en service.

Risque de destruction par des décharges électrostatiques
Les composants CMOS contenus dans le codeur sont très sensibles aux décharges électrostatiques provoquées par exemple par le frottement de certains vêtements.
→ Ne pas toucher aux contacts enfichables ni aux composants électroniques.

Risque de destruction par des surcharges mécaniques
Une fixation rigide conduit à une contrainte permanente sur les paliers due aux forces de réaction.
→ Ne jamais entraver le mouvement de l'arbre du codeur. Pour la fixation, utiliser uniquement les tôles élastiques à ressorts livrées avec le codeur ou un accouplement adéquat.

Risque de destruction par des chocs mécaniques
De fortes vibrations ou des chocs, par ex. des coups de marteau, peuvent provoquer la destruction du système optique de balayage du codeur et des roulements à billes.
→ Ne jamais forcer. Un montage correct permet un assemblage facile des éléments.

Risque de destruction par surcharge
→ Mettre l'appareil en œuvre uniquement dans les limites prescrites sur les notices techniques.

Domaine d'application : commandes et processus industriels.
Les surtensions sur les bornes de raccordement doivent être limitées aux valeurs de la catégorie II concernant les surtensions (SELV).
Ce codeur correspond à une fourniture prévue pour être intégrée dans un appareil (moteur, partie mécanique). Il n'est pas destiné à la vente directe au client final.
Le constructeur intégrant ce codeur dans son équipement est tenu de respecter les directives CE ainsi que le marquage CE.

D 1. Vorwort
Dieses Anleitung soll Ihnen den Anschluss und die Inbetriebnahme des Drehgebers ermöglichen.
Weitere Informationen finden Sie im Drehgeberkatalog bzw. erhalten Sie auf Anfrage oder per Download von unserer Internetseite.
www.hengstler.de

GB 1. Preface
These installation instructions are provided for the connection and starting procedure of your shaft encoder.
You will get further information from the Acuro datasheet, on request or on download from our Internet site.
www.hengstler.de

F 1. Avant-propos
Ces instructions ont pour but de vous permettre la mise en route du capteur angulaire.
Vous trouverez de plus amples informations dans la fiche technique ou sur simple demande ou par téléchargement à partir de notre site Internet.
www.hengstler.de

I 1. Introduzione
Questo manuale d'installazione ha il compito di darle la possibilità di allacciare e mettere in funzione i trasduttori.
Ulteriori informazioni riceve dal foglio caratteristiche o a richiesta o servitevi di download nel nostro sito internet.
www.hengstler.de

E 1. Prólogo
Este manual de instalación le permite la conexión y puest en marcha de los transmisores giratorios.
Encontrará mayor información en el hoja de especificaciones o obtendrá esta en ruego, o bien, solicítela directamente a nuestra empresa.
www.hengstler.de

D 2. Sicherheitshinweise

Befugte Personen
Der Drehgeber darf nur von einer Elektrofachkraft montiert und demontiert werden, da im Drehgeber empfindliche elektronische Schaltkreise enthalten sind.

Verletzungsgefahr durch rotierende Wellen
Haare und Kleidungsstücke können von rotierenden Wellen erfasst werden.
→ Vor allen Arbeiten alle Betriebsspannungen ausschalten und Arbeitsumgebung sichern!

Zerstörungsgefahr durch Körper elektrizität
Die CMOS-Bausteine im Drehgeber sind sehr empfindlich gegen hohe Spannungen, wie sie z. B. durch die Reibung der Kleidung entstehen können.
→ Steck-Kontakte und elektronische Komponenten nicht berühren!

Zerstörungsgefahr durch mechanische Überlastung
Eine starke Befestigung führt zu dauerhafter Überlastung der Lager durch Zwangskräfte.
→ Die Beweglichkeit der Geberwelle niemals einschränken! Zur Befestigung nur die beigelegten Federbleche oder eine geeignete Kupplung verwenden!

Zerstörungsgefahr durch mechanischen Schock
Starke Erschütterungen, z. B. Hammerschläge, können zur Zerstörung der optischen Abtastung und der Kugellager führen.
→ Niemals Gewalt anwenden! Bei sachgemäßer Montage lässt sich alles leichtgängig zusammenfügen.

Zerstörungsgefahr durch Überlastung
→ Das Gerät darf nur innerhalb der Grenzen betrieben werden, wie sie in den technischen Daten vorgegeben sind.

Anwendungsbereich: Industrielle Prozesse und Steuerungen.
Überspannungen an den Anschlussklemmen müssen auf Werte der Überspannungskategorie II begrenzt werden (SELV).
Das Anschlusskabel ist nicht schleppfähig und nur für feste Verlegung geeignet.
Dieser Geber ist ein Zuliefererteil, das für den Einbau in ein Gerät (Motor, Maschine) vorgesehen ist. Er ist nicht für den Verkauf an den Endkunden bestimmt.
Der Hersteller, der diesen Geber in sein Gerät integriert, ist verantwortlich für die Einhaltung der CE-Richtlinien und die CE-Kennzeichnung.

I 2. Avvertenze sulla Sicurezza

Persone autorizzate
Il trasduttore di rotazione può essere montato e smontato solo da un elettricista specializzato, poiché il trasduttore di rotazione è dotato di circuiti elettronici sensibili.

Pelico di lesioni dovute ad alberi in rotazione
I capelli e gli indumenti possono impigliarsi negli alberi in rotazione.
→ Prima di eseguire qualsiasi lavoro disinserire tutte le tensioni d'esercizio e proteggere la zona di lavoro!

Pelico di distruzione dovuta all'elettricità formatasi nel corpo
I componenti CMOS del trasduttore di rotazione sono molto sensibili alle alte tensioni come quelle che possono formarsi in seguito allo strofinio degli indumenti.
→ Non toccare i connettori a spina ed i componenti elettronici!

Pelico di distruzione dovuta a sovraccarico meccanico
Un fissaggio troppo rigido provoca un sovraccarico permanente dei cuscinetti per via delle forze ad azione forzata.
→ Non limitare mai la mobilità dell'albero del trasduttore! Per il fissaggio utilizzare solo le lamiere elastiche in dotazione oppure un giunto adeguato!

Pelico di distruzione dovuta a shock meccanico
Forti urti, ad esempio i colpi di martello, possono causare la distruzione del sistema di scansione ottica e dei cuscinetti a sfera.
→ Non usare violenza! Lavorando appropriatamente si può unire tutto più facilmente.
→ Pelico di distruzione dovuta a sovraccarico.
Fare funzionare l'apparecchio entro i limiti che sono stati specificati nelle caratteristiche tecniche

Campo d'impiego: processi industriali e dispositivi di comando.
Le sovratensioni sui morsetti devono essere limitate ai valori della categoria di sovratensione II (SELV).
Questo trasduttore è un elemento complementare destinato al montaggio in un apparecchio (motore, macchina), e non può essere venduto al cliente finale.
Il produttore che incorpora questo trasduttore nel suo apparecchio è tenuto a far rispettare le direttive CE e a farlo contrassegnare col marchio CE.

E 2. Seguridad

Persona autorizada
Dado que el codificador rotatorio contiene circuitos electrónicos sensibles, únicamente un electricista especializado está autorizado a montarlo y a desmontarlo.

Peligo de lesión mediante ejes en rotación
Los cabellos y las prendas de vestir pueden ser arrastrados por los ejes en rotación.
→ ¡Antes de comenzar cualquier trabajo, desconecte todas las tensiones de alimentación y asegure el entorno de trabajo!

Peligo de destrucción por electricidad electrostática
Los componentes de CMOS del codificador rotatorio son muy sensibles a las altas tensiones, que se producen p.ej. por el frotamiento de la ropa.
→ ¡No toque los contactos enchufables y componentes electrónicos!

Peligo de destrucción por sobrecarga mecánica
Un soporte rígido produce una sobrecarga permanente de los cojinetes ocasionada por las fuerzas de ligadura.
→ ¡No limite nunca la libertad de movimiento del eje del codificador! ¡Para fijarlo, utilice únicamente las chapas elásticas adjuntadas o un dispositivo de acoplamiento adecuado!

Peligo de destrucción por choque mecánico
Las vibraciones fuertes, p.ej. las que se producen por los golpes de un martillo, pueden destruir el dispositivo de exploración óptica y los rodamientos de bolas.
→ ¡No recurra nunca a la violencia! El montaje es sencillo, siempre y cuando se sigan los pasos correctos.

Peligo de destrucción por sobrecarga
→ No está permitido utilizar el aparato fuera de los límites prescritos en la hoja de datos técnicos.

Campo de aplicación: Procesos industriales y unidades de mando.
Es imprescindible limitar las sobretensiones en los bornes de conexión a los valores correspondientes a la categoría de sobretensión II (SELV).
Este codificador forma parte del suministro y está destinado a la instalación en un aparato (motor, máquina). No está previsto para la venta al cliente.
Todo fabricante, que integre este codificador en uno de sus aparatos, se responsabiliza por el cumplimiento de la normativa CE y de la marca CE.

3. Montage • Assembly • Montage • Montaggio • Montaje

A Synchroflansch • Synchro flange

B Klemmflansch • Clamping Flange

C Quadratflansch • Square Flange

(A) Klemmflansch
Clamping flange

(B) Montage über Befestigungsgewinde
Mounting by fastening threads

4. Maßzeichnung • Dimensioned Drawings • Schema d'encombrement • Dimensioni • Plano acotado

Connection	Output	Axial L1 mm	Radial L2 mm
cable	R (with UB = DC 5 V), T, K, I	51.5	41.5
	R (with UB = DC 10-30 V)	56	56
M23-connector (CONIN)	R (with UB = DC 5 V), T, K, I	57.5	51.5
	R (with UB = DC 10-30 V)	57.5	56

Connection	Output	Axial L1 mm	Radial L2 mm
cable	R (with UB = DC 5 V), T, K, I	45.5	35.5
	R (with UB = DC 10-30 V)	50	50
M23-connector (CONIN)	R (with UB = DC 5 V), T, K, I	51.5	45.5
	R (with UB = DC 10-30 V)	51.5	50

5. Kürzel
Codes • Abréviation
Abbreviature • Abreviatura

5.1 Farbkürzel für Kabel
Colour code for cable • Abréviation de couleur de câble
Abbreviature per cavi • Abreviatura de color para cable

ID	D	GB	F	I	E
bl	blau	blue	bleu	blu	azul
br	braun	brown	brun	marrone	marrón
ge	gelb	yellow	jaune	giallo	amarillo
gn	grün	green	vert	verde	verde
gr	grau	grey	gris	grigio	gris
rs	rosa	pink	rose	rosa	rosa
rt	rot	red	rouge	rosso	rojo
sw	schwarz	black	noir	nero	negro
vi	violett	violet	violet	viola	violeta
ws	weiß	white	blanc	bianco	blanco

5.2 Kürzel für Ausgangsschaltung
Code for output • Abréviation de étage de sortie
Abbreviature per uscita • Abreviatura de salida

ID	D	GB	F	I	E
R	RS 422 + Alarm	RS 422 + Alarm	RS 422 + alarme	RS 422 + Allarme	RS 422 + Alarma
T	RS 422 + Sense	RS 422 + Sense	RS 422 + sense	RS 422 + Sonda	RS 422 + Sense
K	HTL	push-pull	HTL	push-pull	contrafase
I	HTL komplementär	push-pull complementary	HTL complémentaire	push-pull antivalente	contrafase antivalente

6. Mechanische Daten
Mechanical data • Caractéristiques mécaniques
Dati meccanici • Datos mecánicos

d = 12mm: F_r = 80N; F_a = 60N
d = 7..10mm: F_r = 60N; F_a = 40N
d = 6/6,35mm: F_r = 40N; F_a = 20N

$n_{max} = 10000 \text{ min}^{-1}$

• Betrieb
• Operation
• De fonctionnement
• Esercizio
• Servicio

RI58-O / RI59: -10 ... +70 °C
RI58-T: -25 ... +100 °C

7. Elektrische Daten
Electrical data • Caractéristiques électriques
Dati elettrici • Datos eléctricos

	T	R	K, I
• Versorgungsspannung • Power supply • Alimentation • Tensione d'alimentazione • Tension de alimentacion	DC 5V±10%	DC 5V±10% or DC 10...30V	DC 10...30V
I _{max} (only Encoder) =	max. 40 mA (DC 5V), 60 mA (DC 10V), 30 mA (DC 24V)		
ESD			

8. Anschlussbilder
Connection diagrams • Symboles de raccordement
Denominazione collegamento • Denominación de los cables

8.1 Kabel • Cable • Câble • Cavo • Cable

Farbe • Colour • Couleur • Cavi • Color	Ausgangsschaltung • Output • Etage de sortie • Uscita • Salida			
	PVC (A,B)	TPE (E,F)	R, T, I	K
rt	br/gn	DC 5/10-30 V	DC 10-30 V	
ge/rt	bl	Sense V _{cc}		
ws	br	Channel A	Channel A	
ws/br	gn	Channel A	Channel A	
gn	gr	Channel B	Channel B	
gn/br	rs	Channel B	Channel B	
ge	rt	Channel N	Channel N	
ge/br	sw	Channel N	Channel N	
sw	ws/gn	GND	GND	
ge/sw	vi (ws) ¹	Alarm/Sense GND	Alarm	
screen ²	screen ²	screen ²	screen ²	

¹ ws if RS422 + Sense (T)
² Connected with encoder housing

8.2 Connector M23, 12 Pole (CONIN)

PIN	RS 422 + Sense (T)	RS 422 + Alarm (R)	push-pull (K)	push-pull complementary (I)
1	Channel B	Channel B	N.C.	Channel B
2	Sense V _{cc}	Sense V _{cc}	N.C.	Sense V _{cc}
3	Channel N	Channel N	Channel N	Channel N
4	Channel N	Channel N	N.C.	Channel N
5	Channel A	Channel A	Channel A	Channel A
6	Channel A	Channel A	N.C.	Channel A
7	N.C.	Alarm	Alarm	Alarm
8	Channel B	Channel B	Channel B	Channel B
9	N.C.	N.C.	N.C.	N.C.
10	GND	GND	GND	GND
11	Sense GND	N.C.	N.C.	N.C.
12	DC 5 V	DC 5 V/10-30 V	DC 10-30 V	DC 10-30 V

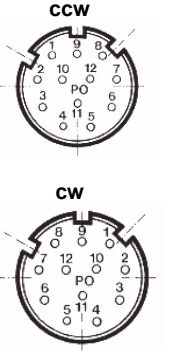

8.3 Connector 10 Pole (MIL)

PIN	Description RS 422/ Euro-pinout (Connection codes O and K)	push-pull	push-pull complementary
1/A	Channel A	Channel A	Channel A
2/B	Channel B	Channel B	Channel B
3/C	Channel N	Channel N	Channel N
4/D	DC 5/10-30 V	DC 10-30 V	DC 10-30 V
5/E	Alarm	Alarm	Alarm
6/F	GND	GND	GND
7/G	Channel A	screen	Channel A
8/H	Channel B	N.C.	Channel B
9/I	Channel N	N.C.	Channel N
10/J	screen	screen	screen

8.4 Connector M16, 6 Pole (BINDER)

PIN	Description (push-pull)
1	DC 10-30 V
2	Channel A
3	Channel N
4	Channel B
5	Alarm
6	GND

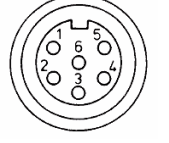

9. Identifikationscode
Ordering data • Code d'identification
Chiave per l'ordinazione • Código de pedido

9.1 Deutsch

Typ	Ausführung	Auflösung	Versorgung	Flansch, Schutzart, Welle	Ausgang	Anschluss
RI58-RI59	O Standard T Hochtemperatur	RI58-O / RI59: 1...10000 Striche RI58-T: 4...2500 Striche	A DC 5 V E DC 10-30 V (nur mit Gegentakt)	K.43 Klemm Ø58, IP65/64, 7mm K.46 Klemm Ø58, IP65/64, 9,52mm K.42 Klemm Ø58, IP65/64, 10mm K.47 Klemm Ø58, IP65/64, 12mm K.72 Klemm Ø58, IP67/67, 9,52mm S.41 Synchro Ø58, IP65/64, 6mm S.45 Synchro Ø58, IP65/64, 6,35mm S.71 Synchro Ø58, IP67/67, 6mm S.75 Synchro Ø58, IP67/67, 6,35mm M.46 Syn.klemm Ø63,5, IP65/64, 9,52mm M.76 Syn.klemm Ø63,5, IP67/67, 9,52mm Q.46 Quadrat 63,5 x 63,5, IP65/64, 9,52mm Q.42 Quadrat 63,5 x 63,5, IP65/64, 10mm Q.76 Quadrat 63,5 x 63,5, IP67/67, 9,52mm Q.72 Quadrat 63,5 x 63,5, IP67/67, 10mm G.43 Quadrat 80 x 80, IP67/67, 7mm RI59: Q.7A Quadrat 63,5 x 63,5, IP67, 10 x 25 mm Q.7B Quadrat 63,5 x 63,5, IP67, 9,25 x 25 mm	T RS422 + Sense K Gegentakt, kurzschlussfest I Gegentakt, antivalent R RS422 + Alarm	A PVC-Kabel, axial B PVC-Kabel, radial C CONIN, axial, cw D CONIN, radial, cw E TPE-Kabel, axial F TPE-Kabel, radial G CONIN, axial, ccw H CONIN, radial, ccw J BINDER, 6pol., radial N BINDER, 6pol., axial O MIL MS, 10pol., axial K MIL MS, 10pol., radial

9.2 Englisch

Type	Model	Number of pulses	Supply voltage	Flange, Protection, Shaft	Output	Connection
RI58-RI59	O Standard T High-temperature	RI58-O / RI59: 1...10000 RI58-T: 4...2500	A DC 5 V E DC 10-30 V (Only with push-pull)	K.43 Clamping Ø58, IP65/64, 7mm K.46 Clamping Ø58, IP65/64, 9,52mm K.42 Clamping Ø58, IP65/64, 10mm K.47 Clamping Ø58, IP65/64, 12mm K.72 Clamping Ø58, IP67/67, 9,52mm S.41 Synchro Ø58, IP65/64, 6mm S.45 Synchro Ø58, IP65/64, 6,35mm S.71 Synchro Ø58, IP67/67, 6mm S.75 Synchro Ø58, IP67/67, 6,35mm M.46 Syn.clamping Ø63,5, IP65/64, 9,52mm M.76 Syn.clamping Ø63,5, IP67/67, 9,52mm Q.46 Square 63,5 x 63,5, IP65/64, 9,52mm Q.42 Square 63,5 x 63,5, IP65/64, 10mm Q.76 Square 63,5 x 63,5, IP67/67, 9,52mm Q.72 Square 63,5 x 63,5, IP67/67, 10mm G.43 Square 80 x 80, IP67/67, 7mm RI59: Q.7A Square 63,5 x 63,5, IP67, 10 x 25 mm Q.7B Square 63,5 x 63,5, IP67, 9,25 x 25 mm	T RS422 + Sense K push-pull, short circuit proof I push-pull complementary R RS422 + Alarm	A PVC-cable, axial B PVC-cable, radial C CONIN, axial, cw D CONIN, radial, cw E TPE-cable, axial F TPE-cable, radial G CONIN, axial, ccw H CONIN, radial, ccw J BINDER, 6 pole, axial N BINDER, 6 pole, axial O MIL MS, 10 pole, axial K MIL MS, 10 pole, radial

9.4 Italiano

Tipo	Modello	Numeri impulsi	Tensione d'alimentazione	Fissaggio, Tipo di protezione, Diametro albero	Uscita	Tipo di collegamento
RI58-RI59	O Standard T Alta-temperatura	RI58-O / RI59: 1...10000 RI58-T: 4...2500	A DC 5 V E DC 10-30 V	K.43 Flangia di serraggio Ø58, IP65/64, 7mm K.46 Flangia di serraggio Ø58, IP65/64, 9,52mm K.42 Flangia di serraggio Ø58, IP65/64, 10mm K.47 Flangia di serraggio Ø58, IP65/64, 12mm K.72 Flangia di serraggio Ø58, IP67/67, 9,52mm S.41 Flangia sincrona Ø58, IP65/64, 6mm S.45 Flangia sincrona Ø58, IP65/64, 6,35mm S.71 Flangia sincrona Ø58, IP67/67, 6mm S.75 Flangia sincrona Ø58, IP67/67, 6,35mm M.46 Flangia di serraggio sincrona Ø63,5, IP65/64, 9,52mm M.76 Flangia di serraggio sincrona Ø63,5, IP67/67, 9,52mm Q.46 Flangia quadrata 63,5 x 63,5, IP65/64, 9,52mm Q.42 Flangia quadrata 63,5 x 63,5, IP65/64, 10mm Q.76 Flangia quadrata 63,5 x 63,5, IP67/67, 9,52mm Q.72 Flangia quadrata 63,5 x 63,5, IP67/67, 10mm G.43 Flangia quadrata 80 x 80, IP67/67, 7mm RI59: Q.7A Flangia quadrata 63,5 x 63,5, IP67, 10 x 25mm Q.7B Flangia quadrata 63,5 x 63,5, IP67, 9,25 x 25mm	T RS422 + Sonda K push-pull anticortocircuito I push-pull, antivalente R RS422 + Allarme	A PVC-cavo, assiale B PVC-cavo, radiale C CONIN, assiale, cw D CONIN, radiale, cw E TPE-cavo, assiale F TPE-cavo, radiale G CONIN, assiale, ccw H CONIN, radiale, ccw J BINDER, 6pol., radiale N BINDER, 6pol., assiale O MIL MS, 10pol., assiale K MIL MS, 10pol., radiale

9.5 Español

Tipo	Model	Cantidad de líneas	Tensión de alimentación	Sujeción, Tipo de protección, Diámetro del eje	Salida	Tipo de conexión
RI58-RI59	O Standard T Temperatura alta	RI58-O / RI59: 1...10000 RI58-T: 4...2500	A CC 5 V E CC 10-30 V	K.43 Brida de apriete Ø58, IP65/64, 7mm K.46 Brida de apriete Ø58, IP65/64, 9,52mm K.42 Brida de apriete Ø58, IP65/64, 10mm K.47 Brida de apriete Ø58, IP65/64, 12mm K.72 Brida de apriete Ø58, IP67/67, 9,52mm S.41 Acoplamiento sincrónico Ø58, IP65/64, 6mm S.45 Acoplamiento sincrónico Ø58, IP65/64, 6,35mm S.71 Acoplamiento sincrónico Ø58, IP67/67, 6mm S.75 Acoplamiento sincrónico Ø58, IP67/67, 6,35mm M.46 Brida de apriete sincrónico Ø63,5, IP65/64, 9,52mm M.76 Brida de apriete sincrónico Ø63,5, IP67/67, 9,52mm Q.46 Brida cuadrada 63,5 x 63,5, IP65/64, 9,52mm Q.42 Brida cuadrada 63,5 x 63,5, IP65/64, 10mm Q.76 Brida cuadrada 63,5 x 63,5, IP67/67, 9,52mm Q.72 Brida cuadrada 63,5 x 63,5, IP67/67, 10mm G.43 Brida cuadrada 80 x 80, IP67/67, 7mm RI59: Q.7A Brida cuadrada 63,5 x 63,5, IP67, 10 x 25mm Q.7B Brida cuadrada 63,5 x 63,5, IP67, 9,25 x 25mm	T RS422 + Sense K Contrafase protección contra cortocircuito I contrafase, antivalente R RS422 + Alarma	A PVC-cable, axial B PVC-cable, radial C CONIN, axial, cw D CONIN, radial, cw E TPE-cable, axial F TPE-cable, radial G CONIN, axial, ccw H CONIN, radial, ccw J BINDER, 6 polos, axial N BINDER, 6 polos, axial O MIL MS, 10 polos, axial K MIL MS, 10 polos, radial