



The pages in this document have been extracted from a larger document and as such any page numbers are relevant only to the original document.

HENGSTLER

Rotary Encoder Solutions Limited
Dutton Road
Redwither Business Park
Wrexham
LL13 9UL

tel: +44(0) 1978 664722
fax: +44(0) 1978 664733
email: sales@rotaryencodersolutions.com
web: www.rotaryencodersolutions.com

Rotary Encoder Solutions is part of the Industrial Encoders Direct Ltd. Group of Companies and is trading as Industrial Encoders Direct Ltd

The information shown in this document is for reference purposes only and forms no contractual obligation. Any detail in this document may be changed without prior notice. No liability is accepted for any information contained in this document.



HENGSTLER

Incremental Shaft Encoders Type RI 36-H

Industrial types Hollow shaft



- miniature industry encoder for high number of pulses
- short mounting length
- easy mounting procedure
- Application e.g.:
 - Motors
 - Machine tools
 - Packaging Machines
 - Robots
 - Automated SMD equipment

NUMBER OF PULSES

5 / 10 / 20 / 25 / 50 / 60 / 100 / 200 / 250 / 300 / 360 / 500 / 600 / 720 / 1000 / 1024 / 1250 / 1500 / 2000 / 2048 / 2500 / 3000 / 3600
 Other number of pulses on request

TECHNICAL DATA mechanical

Mounting	Clamping shaft (one side open) with clamping ring front
Coupling	Hubshaft with tether
Shaft diameter	4, 6, 8, 10 mm hollow shaft
Angular shaft misalignment max.	±0.15 mm radial, ±0.5 mm axial
Absolute max. speed	max. 10 000 min ⁻¹
Torque	≤ 1 Ncm
Moment of inertia	approx. 3 gcm ²
Protection class (EN 60529)	Housing IP64, bearings IP64
Operating temperature	-10 ... +70 °C
Storage temperature	-25 ... +85 °C
Vibration resistance	100 m/s ² (10 ... 2000 Hz)
Shock resistance	1000 m/s ² (6 ms)
Connection	1.5 m cable ¹ axial or radial
Housing	Aluminium
Weight	approx. 80 g

¹ Other cable length on request

TECHNICAL DATA electrical

General design	as per DIN VDE 0160, protection class III, contamination level 2, overvoltage class II	
Supply voltage (SELV)	with RS 422 (R, T):	DC 5 V ± 10 %
	with push-pull (K, I):	DC 10 - 30 V ²
Max. current w/o load	40 mA (DC 5 V), 60 mA (DC 10 V), 30 mA (DC 24 V)	
Standard output versions ³	RS 422 (R):	A, B, N, \overline{A} , \overline{B} , \overline{N} , \overline{Alarm}
	RS 422 (T):	A, B, N, \overline{A} , \overline{B} , \overline{N} , Sense
	push-pull (K):	A, B, N, \overline{Alarm}
	push-pull complementary (I):	A, B, N, \overline{A} , \overline{B} , \overline{N} , \overline{Alarm}

² Pole protection

³ Output description and technical data see chapter "Technical basics"

Incremental Shaft Encoders Type RI 36-H

Industrial types Hollow shaft

DIMENSIONAL DRAWINGS

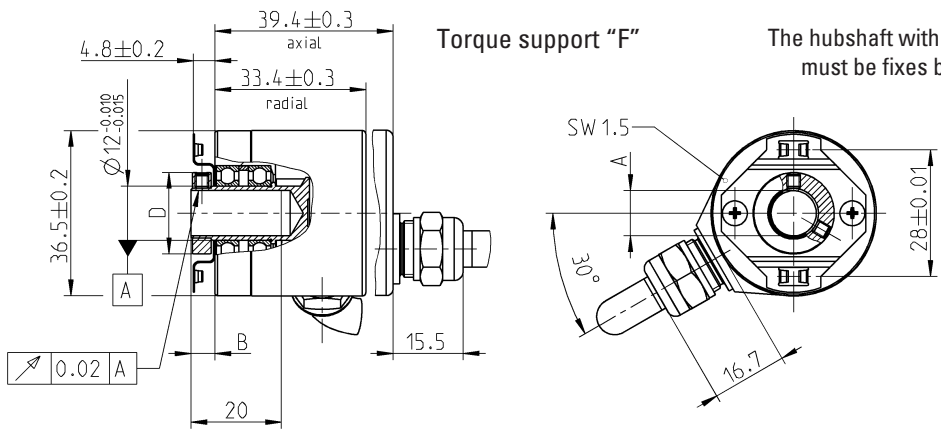
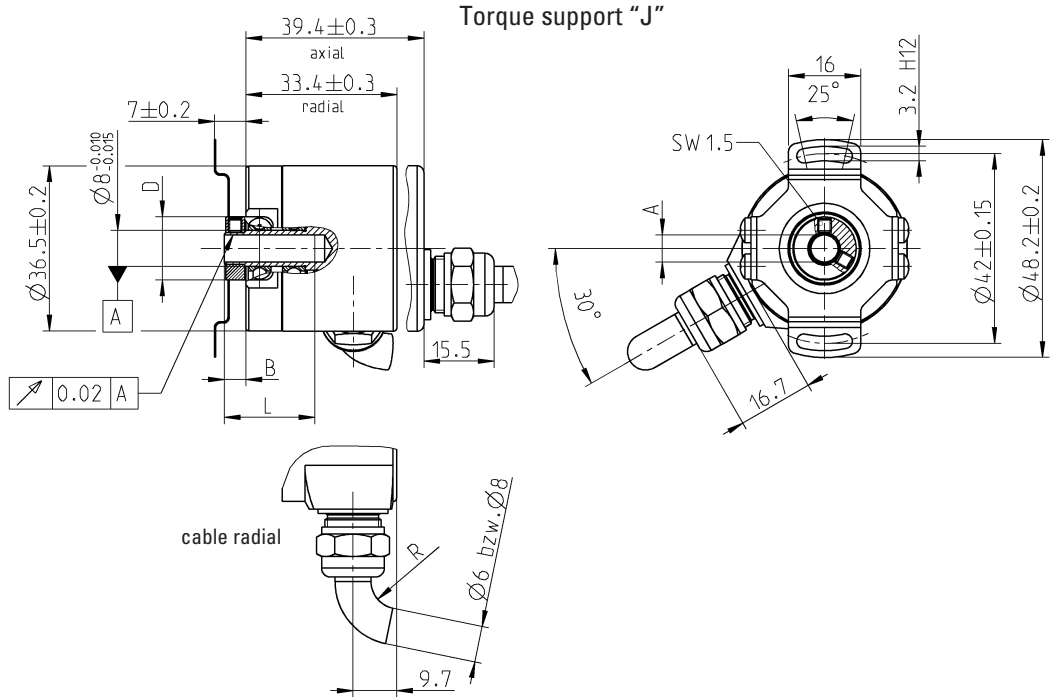

The hubshaft with tether (F) as torque support must be fixed by a cylindrical pin (2.4 mm Ø) at the machine side

Dim.:	Hollow shaft Ø				Unit
A	4 +0.01	6 +0.01	8 +0.01	10 +0.01	mm
A*	4 g7	10 g7	8 g7	10 g7	mm
B	4.8±0.2	4.8±0.2	5.3±0.2	5.3±0.2	mm
D	12	14	16	18	mm
L min	6	9	12	15	mm
L max	20	20	20	20	mm

- A* = diameter of connection shaft
- B = space between housing and shaft
- D = Ø clamping ring
- L = length of connection shaft

R for alternating bending ≥ 100 mm
 R for permanent bending ≤ 40 mm

Tightening torque of set screw 15 Ncm

Dimensions in mm

Incremental Shaft Encoders Type RI 36-H

Industrial types Hollow shaft

PIN ASSIGNMENT

Cable PVC (A, B)		Output		
Colour	Litze mm ²	RS 422 (R, T)	push-pull (K)	push-pull complementary (I)
red	0.5	DC 5 V	DC 10 - 30 V	DC 10 - 30 V
yellow/red	0.14	Sense V _{CC}		Sense V _{CC}
white	0.14	Channel A	Channel A	Channel A
white/brown	0.14	Channel \bar{A}		Channel \bar{A}
green	0.14	Channel B	Channel B	Channel B
green/brown	0.14	Channel \bar{B}		Channel \bar{B}
yellow	0.14	Channel N	Channel N	Channel N
yellow/brown	0.14	Channel \bar{N}		Channel \bar{N}
black	0.5	GND	GND	GND
yellow/black	0.14	Alarm /Sense GND ¹	Alarm	Alarm
screen ²		screen ²	screen ²	screen ²

¹ depending on ordering code

² connected with encoder housing

ORDERING INFORMATION

Type	Model	Number of pulses	Supply voltage	Flange, Protection, Shaft	Output	Connection
<input type="checkbox"/>	<input type="checkbox"/>	<input type="text"/>	<input type="checkbox"/>	<input type="text"/>	<input type="checkbox"/>	<input type="checkbox"/>
RI36-	H Hollow shaft	5 ... 3 600	A DC 5 V E DC 10 - 30 V (only with push-pull)	F.30 Clamping, IP64, 4 mm * F.31 Clamping, IP64, 6 mm * F.3C Clamping, IP64, 8 mm * F.32 Clamping, IP64, 10 mm * J.30 Clamping, IP64, 4 mm ** J.31 Clamping, IP64, 6 mm ** J.3C Clamping, IP64, 8 mm ** J.32 Clamping, IP64, 10 mm **	T RS 422 + Sense K push-pull short circuit proof R RS 422 + Alarm I push-pull complementary	A Cable axial B Cable radial
* Fixing of hubshaft with tether by cylindrical pin ** Fixing of hubshaft with tether by oblong hole						



HENGSTLER

Hotline
+49 (0) 74 24 / 89 - 0

HENGSTLER GmbH
Uhlandstr. 49
D-78554 Aldingen
http://www.hengstler.de
e-mail: info@hengstler.de

HENGSTLER

- D** Inkrementeller Drehgeber
RI 36-H
Installationsanleitung
- GB** Incremental Encoders
RI 36-H
Installation instructions
- F** Codeur incrémental
RI 36-H
Instructions d'installation
- I** Trasduttori incrementali
RI 36-H
Istruzioni di installazione
- E** Transmisores giratorios incrementales
RI 36-H
Instrucciones de instalación

Art. No.: 2 521 354
Edition.: 3 290906 MM

GB 2. Safety

Authorised persons
The encoder should only be assembled and dismantled by a qualified electrician, as the unit contains sensitive electronic circuits.

Risk of injury due to rotating shafts
Hair and items of clothing may become caught up in rotating shafts.
→ Prior to commencing all works, disconnect all power supplies and ensure that the working environment is safe!

Risk of destruction due to static electricity
The CMOS modules contained in the encoder are very sensitive to high voltages such as can arise due to friction of the clothing.
→ Do not touch plug contacts or electronic components!

Risk of destruction due to mechanical overload
Rigid mounting will give rise to constraining forces which will permanently overload the bearings.
→ Never restrict the freedom of movement of the encoder! Use only the enclosed sheet steel springs or a suitable coupling to secure the unit!

Risk of destruction due to mechanical shock
Violent shocks, e.g. due to hammer blows, can lead to the destruction of the optical sensing system and the ball bearings.
→ Never use force! Assembly is simple provided that correct procedure is followed.

Risk of destruction due to overloading
→ The unit may only be operated within the limits specified in the technical data.

Fields of application: industrial processes and controls.
Over voltage at the connecting terminals must be limited to over voltage-class-II values (SELV).
The connecting cable is not for dragline mounting, only for fix mounting.
This encoder is a supply part destined for mounting to an appliance (motor, machine). It is not provided for customer sale.
Manufacturers integrating this encoder to their facilities are responsible as well for compliance with CE guidelines as for the CE mark.

F 2. Sécurité

Personnel autorisé
Du fait que le codeur renferme des circuits électroniques sensibles, seul le personnel compétent est autorisé à monter ou démonter le codeur.

Mise en garde contre les arbres en rotation
Les cheveux et les vêtements peuvent être happés par les arbres en rotation.
→ Prière de sécuriser l'environnement de travail avant de mettre les machines en service.

Risque de destruction par des décharges électrostatiques
Les composants CMOS contenus dans le codeur sont très sensibles aux décharges électrostatiques provoquées par exemple par le frottement de certains vêtements.
→ Ne pas toucher aux contacts enfichables ni aux composants électroniques.

Risque de destruction par des surcharges mécaniques
Une fixation rigide conduit à une contrainte permanente sur les paliers due aux forces de réaction.
→ Ne jamais entraver le mouvement de l'arbre du codeur. Pour la fixation, utiliser uniquement les tôles élastiques à ressorts livrées avec le codeur ou un accouplement adéquat.

Risque de destruction par des chocs mécaniques
De fortes vibrations ou des chocs, par ex. des coups de marteau, peuvent provoquer la destruction du système optique de balayage du codeur et des roulements à billes.
→ Ne jamais forcer. Un montage correct permet un assemblage facile des éléments.

Risque de destruction par surcharge
→ Mettre l'appareil en œuvre uniquement dans les limites prescrites sur les notices techniques.

Domaine d'application : commandes et processus industriels.
Les surtensions sur les bornes de raccordement doivent être limitées aux valeurs de la catégorie II concernant les surtensions (SELV).
Ce codeur correspond à une fourniture prévue pour être intégrée dans un appareil (moteur, partie mécanique). Il n'est pas destiné à la vente directe au client final.
Le constructeur intégrant ce codeur dans son équipement est tenu de respecter les directives CE ainsi que le marquage CE.

D 1. Vorwort
Dieses Anleitung soll Ihnen den Anschluss und die Inbetriebnahme des Drehgebers ermöglichen.
Weitere Informationen finden Sie im Drehgeberkatalog bzw. erhalten Sie auf Anfrage oder per Download von unserer Internetseite.
www.hengstler.de

GB 1. Preface
These installation instructions are provided for the connection and starting procedure of your shaft encoder.
You will get further information from the Acuro datasheet, on request or on download from our Internet site.
www.hengstler.de

F 1. Avant-propos
Ces instructions ont pour but de vous permettre la mise en route du capteur angulaire.
Vous trouverez de plus amples informations dans le fiche technique ou sur simple demande ou par téléchargement à partir de notre site Internet.
www.hengstler.de

I 1. Introduzione
Questo manuale d'installazione ha il compito di darle la possibilità di allacciare e mettere in funzione il trasduttore.
Ulteriori informazioni riceve dal foglio caratteristiche o a richiesta o servitevi di download nel nostro sito internet.
www.hengstler.de

E 1. Prámbulo
Este manual de instalación le permite la conexión y puest en marcha de los transmisores giratorios.
Encontrará mayor información en el hoja de especificaciones o obtendrá esta en ruego, o bien, solicítela directamente a nuestra empresa.
www.hengstler.de

D 2. Sicherheitshinweise

Befugte Personen
Der Drehgeber darf nur von einer Elektrofachkraft montiert und demontiert werden, da im Drehgeber empfindliche elektronische Schaltkreise enthalten sind.

Verletzungsgefahr durch rotierende Wellen
Haare und Kleidungsstücke können von rotierenden Wellen erfasst werden.
→ Vor allen Arbeiten alle Betriebsspannungen ausschalten und Arbeitsumgebung sichern!

Zerstörungsgefahr durch Körperelektrizität
Die CMOS-Bausteine im Drehgeber sind sehr empfindlich gegen hohe Spannungen, wie sie z. B. durch die Reibung der Kleidung entstehen können.
→ Steck-Kontakte und elektronische Komponenten nicht berühren!

Zerstörungsgefahr durch mechanische Überlastung
Eine starke Befestigung führt zu dauerhafter Überlastung der Lager durch Zwangskräfte.
→ Die Beweglichkeit der Geberwelle niemals einschränken! Zur Befestigung nur die beigelegten Federbleche oder eine geeignete Kupplung verwenden!

Zerstörungsgefahr durch mechanischen Schock
Starke Erschütterungen, z. B. Hammerschläge, können zur Zerstörung der optischen Abtastung und der Kugellager führen.
→ Niemals Gewalt anwenden! Bei sachgemäßer Montage lässt sich alles leichtgängig zusammenfügen.

Zerstörungsgefahr durch Überlastung
→ Das Gerät darf nur innerhalb der Grenzen betrieben werden, wie sie in den technischen Daten vorgegeben sind.

Anwendungsbereich: Industrielle Prozesse und Steuerungen.
Überspannungen an den Anschlussklemmen müssen auf Werte der Überspannungskategorie II begrenzt werden (SELV).
Das Anschlusskabel ist nicht schleppfähig und nur für feste Verlegung geeignet.
Dieser Geber ist ein Zulieferteil, das für den Einbau in ein Gerät (Motor, Maschine) vorgesehen ist. Er ist nicht für den Verkauf an den Endkunden bestimmt.
Der Hersteller, der diesen Geber in sein Gerät integriert, ist verantwortlich für die Einhaltung der CE-Richtlinien und die CE-Kennzeichnung.

I 2. Avvertenze sulla Sicurezza

Persone autorizzate
Il trasduttore di rotazione può essere montato e smontato solo da un elettricista specializzato, poiché il trasduttore di rotazione è dotato di circuiti elettronici sensibili.

Piccolo di lesioni dovute ad alberi in rotazione
I capelli e gli indumenti possono impigliarsi negli alberi in rotazione.
→ Prima di eseguire qualsiasi lavoro disinserire tutte le tensioni d'esercizio e proteggere la zona di lavoro!

Piccolo di distruzione dovuta all'elettricità formatasi nel corpo
I componenti CMOS del trasduttore di rotazione sono molto sensibili alle alte tensioni come quelle che possono formarsi in seguito allo strofinio degli indumenti.
→ Non toccare i connettori a spina ed i componenti elettronici!

Piccolo di distruzione dovuta a sovraccarico meccanico
Un fissaggio troppo rigido provoca un sovraccarico permanente dei cuscinetti per via delle forze ad azione forzata.
→ Non limitare mai la mobilità dell'albero del trasduttore! Per il fissaggio utilizzare solo le lamiere elastiche in dotazione oppure un giunto adeguato!

Piccolo di distruzione dovuta a shock meccanico
Forti urti, ad esempio i colpi di martello, possono causare la distruzione del sistema di scansione ottica e dei cuscinetti a sfera.
→ Non usare violenza! Lavorando appropriatamente si può unire tutto più leggeremente.
→ Pericolo di distruzione dovuta a sovraccarico.
Fare funzionare l'apparecchio entro i limiti che sono stati specificati nelle caratteristiche tecniche

Campo d'impiego: processi industriali e dispositivi di comando.
Le sovrattensioni sui morsetti devono essere limitate ai valori della categoria di sovrattensione II (SELV).
Questo trasduttore è un elemento complementare destinato al montaggio in un apparecchio (motore, macchina), e non può essere venduto al cliente finale.
Il produttore che incorpora questo trasduttore nel suo apparecchio è tenuto a far rispettare le direttive CE e a farlo contrassegnare col marchio CE.

E 2. Seguridad

Persona autorizada
Dado que el codificador rotatorio contiene circuitos electrónicos sensibles, únicamente un electricista especializado está autorizado a montarlo y a desmontarlo.

Peligro de lesión mediante ejes en rotación
Los cabellos y las prendas de vestir pueden ser arrastrados por los ejes en rotación.
→ ¡Antes de comenzar cualquier trabajo, desconecte todas las tensiones de alimentación y asegure el entorno de trabajo!

Peligro de destrucción por electricidad electrostática
Los componentes de CMOS del codificador rotatorio son muy sensibles a las altas tensiones, que se producen p.ej. por el frotamiento de la ropa.
→ ¡No toque los contactos enchufables y componentes electrónicos!

Peligro de destrucción por sobrecarga mecánica
Un soporte rígido produce una sobrecarga permanente de los cojinetes ocasionada por las fuerzas de ligadura.
→ ¡No limite nunca la libertad de movimiento del eje del codificador! ¡Para fijarlo, utilice únicamente las chapas elásticas adjuntadas o un dispositivo de acoplamiento adecuado!

Peligro de destrucción por choque mecánico
Las vibraciones fuertes, p.ej. las que se producen por los golpes de un martillo, pueden destruir el dispositivo de exploración óptica y los rodamientos de bolas.
→ ¡No recurra nunca a la violencia! El montaje es sencillo, siempre y cuando se sigan los pasos correctos.

Peligro de destrucción por sobrecarga
→ No está permitido utilizar el aparato fuera de los límites prescritos en la hoja de datos técnicos.

Campo de aplicación: Procesos industriales y unidades de mando.
Es imprescindible limitar las sobretensiones en los bornes de conexión a los valores correspondientes a la categoría de sobretensión II (SELV).
Este codificador forma parte del suministro y está destinado a la instalación en un aparato (motor, máquina). No está previsto para la venta al cliente.
Todo fabricante, que integre este codificador en uno de sus aparatos, se responsabiliza por el cumplimiento de la normativa CE y de la marca CE.

3. Montage • Assembly • Montage • Montaggio • Montaje

A Drehmomentstütze „F“ • Tether „F“ • Puntale a torisone „F“ • Apoy contra torisone „F“

B Drehmomentstütze „J“ • Tether „J“ • Puntale a torisone „J“ • Apoyo contra torisone „J“

4. Maßzeichnung • Dimensioned Drawings • Schema d'encombrement • Dimensioni • Plano acotado

Drehmomentstütze „F“ • Tether „F“ • Puntale a torisone „F“ • Apoy contra torisone „F“

Drehmomentstütze „J“ • Tether „J“ • Puntale a torisone „J“ • Apoyo contra torisone „J“

Dim.:	Hollow shaft Ø				Unit
A	4 +0.01	6 +0.01	8 +0.01	10 +0.01	mm
A*	4 g7	10 g7	8 g7	10 g7	mm
B	4.8±0.2	4.8±0.2	5.3±0.2	5.3±0.2	mm
D	12	14	16	18	mm
L min	6	9	12	15	mm
L max	20	20	20	20	mm

5. Kürzel
Codes • Abréviation
Abbreviatura • Abreviatura

5.1 Farbkürzel für Kabel
Colour code for cable • Abréviation de couleur de câble
Abbreviatura per cavi • Abreviatura de color para cable

ID	D	GB	F	I	E
bl	blau	blue	bleu	blu	azul
br	braun	brown	brun	marrone	marrón
ge	gelb	yellow	jaune	giallo	amarillo
gn	grün	green	vert	verde	verde
gr	grau	grey	gris	grigio	gris
rs	rosa	pink	rose	rosa	rosa
rt	rot	red	rouge	rosso	rojo
sw	schwarz	black	noir	nero	negro
vi	violett	violett	violet	viola	violeta
ws	weiß	white	blanc	bianco	blanco

5.2 Kürzel für Ausgangsschaltung
Code for output • Abréviation de étage de sortie
Abbreviatura per uscita • Abreviatura de salida

ID	D	GB	F	I	E
R	RS 422 + Alarm	RS 422 + Alarm	RS 422 + alarme	RS 422 + Allarme	RS 422 + Alarma
T	RS 422 + Sense	RS 422 + Sense	RS 422 + sense	RS 422 + Sonda	RS 422 + Sense
K	HTL	push-pull	HTL	push-pull	contrafase
I	HTL komplementär	push-pull complementary	HTL complémentaire	push-pull antivalente	contrafase antivalente

6. Mechanische Daten
Mechanical data • Caractéristiques mécaniques
Dati meccanici • Datos mecánicos

- Max. Wellenversatz
- Max. shaft misalignment
- Mesalignement maxi. de l'axe
- Schermatura albero mass.
- Desalineacion de eje max.

axial: ± 0,5 mm
radial: ± 0,15 mm



max. 10000 min⁻¹

- Betrieb
- Operation
- De fonctionnement
- Esercizio
- Servicio

- 10 ... + 70 °C

7. Elektrische Daten
Electrical data • Caractéristiques électriques
Dati elettrici • Datos eléctricos

	T	R	K, I
Versorgungsspannung Power supply Alimentation Tensione d'alimentazione Tension de alimentacion	DC 5V±10%	DC 5V±10%	DC 10...30V
I _{max} =	max.: 40 mA (DC 5V), 60 mA (DC 10V), 30 mA (DC 24V)		
ESD			

8. Anschlussbilder
Connection diagrams • Symboles de raccordement
Denominazione collegamento • Denominación de los cables

8.1 Kabel • Cable • Câble • Cavo • Cable

Farbe • Colour • Couleur • Cavi • Color		Ausgangsschaltung • Output • Etage de sortie • Uscita • Salida	
PVC (A,B)	TPE (E,F)	R, T, I	K
rt	br/gn	DC 5/10-30 V	DC 10-30 V
ge/rt	bl	Sense V _{cc}	
ws	br	Channel A	Channel A
ws/br	gn	Channel A	
gn	gr	Channel B	Channel B
gn/br	rs	Channel B	
ge	rt	Channel N	Channel N
ge/br	sw	Channel N	
sw	ws/gn	GND	GND
ge/sw	vi (ws)	Alarm/Sense GND	Alarm
screen ²	screen ²	screen ²	screen ²

²Connected with encoder housing

8.2 Connector M23, 12 Pole

PIN	RS 422 + Sense (T)	RS 422 + Alarm (R)	push-pull (K)	push-pull complementary (I)
1	Channel B	Channel B	N.C.	Channel B
2	Sense V _{cc}	Sense V _{cc}	N.C.	Sense V _{cc}
3	Channel N	Channel N	Channel N	Channel N
4	Channel N	Channel N	N.C.	Channel N
5	Channel A	Channel A	Channel A	Channel A
6	Channel A	Channel A	N.C.	Channel A
7	N.C.	Alarm	Alarm	Alarm
8	Channel B	Channel B	Channel B	Channel B
9	N.C.	N.C.	N.C.	N.C.
10	GND	GND	GND	GND
11	Sense GND	N.C.	N.C.	N.C.
12	DC 5 V	DC 5 V/10-30 V	DC 10-30 V	DC 10-30 V

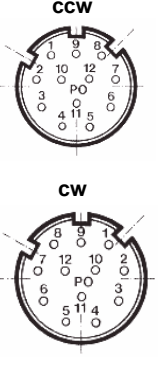

9. Identifikationscode
Ordering data • Code d'identification
Chiave per l'ordinazione • Código de pedido

9.1 Deutsch

Typ	Ausführung	Auflösung	Versorgung	Flansch, Schutzart, Welle	Ausgang	Anschluss
RI36-	H Hohlwelle	5 ... 3600 Striche	A DC 5 V E DC 10-30 V (nur mit Gegentakt)	F.30 Klemm, IP64, 4 mm F.31 Klemm, IP64, 6 mm F.3C Klemm, IP64, 8 mm F.32 Klemm, IP64, 10 mm J.30 Klemm, IP64, 4 mm J.31 Klemm, IP64, 6 mm J.3C Klemm, IP64, 8 mm J.32 Klemm, IP64, 10 mm O.30 Klemm, IP64, 4 mm O.31 Klemm, IP64, 6 mm O.3C Klemm, IP64, 8 mm O.32 Klemm, IP64, 10 mm	T RS422 + Sense K Gegentakt, kurzschlussfest I Gegentakt, antivalent R RS422 + Alarm	A PVC-Kabel, axial B PVC-Kabel, radial E TPE-Kabel, axial F TPE-Kabel, radial

9.2 Englisch

Type	Model	Number of pulses	Supply voltage	Flange, Protection, Shaft	Output	Connection
RI36-	H Hollow shaft	5 ... 3600	A DC 5 V E DC 10-30 V (Only with push-pull)	F.30 Clamping, IP64, 4 mm F.31 Clamping, IP64, 6 mm F.3C Clamping, IP64, 8 mm F.32 Clamping, IP64, 10 mm J.30 Clamping, IP64, 4 mm J.31 Clamping, IP64, 6 mm J.3C Clamping, IP64, 8 mm J.32 Clamping, IP64, 10 mm O.30 Clamping, IP64, 4 mm O.31 Clamping, IP64, 6 mm O.3C Clamping, IP64, 8 mm O.32 Clamping, IP64, 10 mm	T RS422 + Sense K push-pull, short circuit proof I push-pull complementary R RS422 + Alarm	A PVC-Cable, axial B PVC-Cable, radial E TPE-cable, axial F TPE-cable, radial

9.3 Italiano

Tipo	Modello	Numeri impulsi	Tensione d'alimentazione	Fissaggio, Tipo di protezione, Diametro albero	Uscita	Tipo di collegamento
RI36-	H Albero cavo	5 ... 3600	A DC 5 V E DC 10-30 V	F.30 Flangia di serraggio, IP64, 4 mm F.31 Flangia di serraggio, IP64, 6 mm F.3C Flangia di serraggio, IP64, 8 mm F.32 Flangia di serraggio, IP64, 10 mm J.30 Flangia di serraggio, IP64, 4 mm J.31 Flangia di serraggio, IP64, 6 mm J.3C Flangia di serraggio, IP64, 8 mm J.32 Flangia di serraggio, IP64, 10 mm O.30 Flangia di serraggio, IP64, 4 mm O.31 Flangia di serraggio, IP64, 6 mm O.3C Flangia di serraggio, IP64, 8 mm O.32 Flangia di serraggio, IP64, 10 mm	T RS422 + Sonda K push-pull anticortocircuito I push-pull, antivalente R RS422 + Allarme	A PVC-Cavo, assiale B PVC-Cavo, radiale E TPE-Cavo, assiale F TPE-Cavo, radiale

9.4 Español

Tipo	Model	Cantidad de líneas	Tensión de alimentación	Sujeción, Tipo de protección, Diámetro del eje	Salida	Tipo de conexión
RI36-	H eje hueco	5 ... 3600	A CC 5 V E CC 10-30 V	F.30 Brida de apriete, IP64, 4 mm F.31 Brida de apriete, IP64, 6 mm F.3C Brida de apriete, IP64, 8 mm F.32 Brida de apriete, IP64, 10 mm J.30 Brida de apriete, IP64, 4 mm J.31 Brida de apriete, IP64, 6 mm J.3C Brida de apriete, IP64, 8 mm J.32 Brida de apriete, IP64, 10 mm O.30 Brida de apriete, IP64, 4 mm O.31 Brida de apriete, IP64, 6 mm O.3C Brida de apriete, IP64, 8 mm O.32 Brida de apriete, IP64, 10 mm	T RS422 + Sense K Contrafase protección contra cortocircuito I contrafase, antivalente R RS422 + Alarma	A PVC-Cable, axial B PVC-Cable, radial E TPE-cable, axial F TPE-cable, radial