



The pages in this document have been extracted from a larger document and as such any page numbers are relevant only to the original document.

HENGSTLER

Rotary Encoder Solutions Limited
Dutton Road
Redwither Business Park
Wrexham
LL13 9UL

tel: +44(0) 1978 664722
fax: +44(0) 1978 664733
email: sales@rotaryencodersolutions.com
web: www.rotaryencodersolutions.com

Rotary Encoder Solutions is part of the Industrial Encoders Direct Ltd. Group of Companies and is trading as Industrial Encoders Direct Ltd

The information shown in this document is for reference purposes only and forms no contractual obligation. Any detail in this document may be changed without prior notice. No liability is accepted for any information contained in this document.



HENGSTLER

Incremental Shaft Encoders Type RI 32

Economy Types



- Replacement for type RIS and RI 31
- The economical encoder for small appliances
- High efficiency by means of ball bearing
- Small torque
- Application e.g.
 - laboratory equipment
 - training equipment
 - crimping machines
 - tampon printing machines
 - miniature grinding machines

NUMBER OF PULSES

5 / 10 / 20 / 25 / 30 / 50 / 60 / 100 / 120 / 128 / 200 / 250 / 256 / 288 / 300 / 360 / 400 / 500 / 512 / 600 / 720 / 900 / 1000 / 1024 / 1250 / 1500
 Other number of pulses on request

TECHNICAL DATA mechanical

Shaft diameter	5 mm/ 6 mm
Absolute max. shaft load	radial 10 N, axial 5 N
Absolute max. speed	6 000 min ⁻¹
Torque	≤ 0.05 Ncm
Protection class (EN 60529)	Housing IP50, bearings IP40
Operating temperature	-10 ... +60 °C
Storage temperature	-25 ... +85 °C
Vibration resistance (IEC 68-2-6)	100 m/s ² (10 ... 2000 Hz)
Shock resistance (IEC 68-2-27)	1000 m/s ² (6 ms)
Connection	1.5 m cable axial/radial ¹
Material	Housing: plastic; Flange: Aluminium
Flange	Pilot flange
Weight approx.	50 g

¹ Other cable length on request

TECHNICAL DATA electrical

General design	as per DIN VDE 0160, protection class III, contamination level 2, over voltage class II	
Supply voltage (SELV)	with push-pull (D):	DC 5V ±10 %
	with push-pull (K):	DC 5V ¹ ±10 % oder DC 10 - 30V ²
Max. current w/o load	40 mA (DC 5V), 60 mA (DC 10V), 30 mA (DC 24V)	
Standard output versions ³	push-pull (K, D):	A, B, N, Alarm

² Pole protection

³ Output description and technical data see chapter "Technical basics"

Incremental Shaft Encoders Type RI 32

Economy Types

DIMENSIONAL DRAWINGS

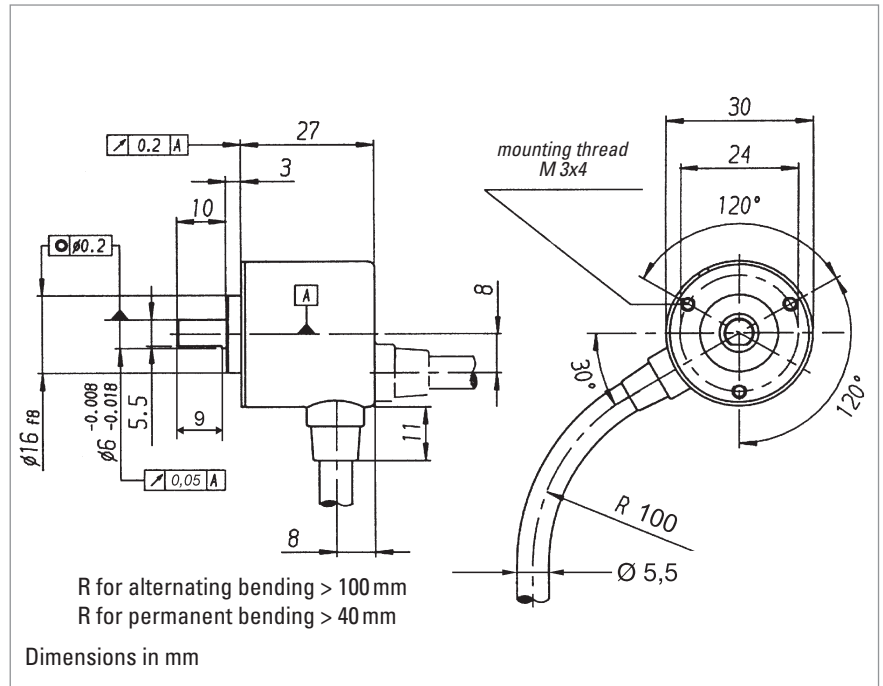

PIN ASSIGNMENT

Description (push-pull)	Lead Ø mm ²	Colour
DC 5 V/ 10 - 30 V	0.5	red
Channel A	0.14	white
Channel B	0.14	green
Channel N	0.14	yellow
GND	0.5	black
Alarm	0.14	yellow/black

ORDERING INFORMATION

Type	Model	Number of pulses	Supply voltage	Flange, Protection, Shaft	Output	Connection
<input type="checkbox"/>	<input type="checkbox"/>	<input type="text"/>	<input type="checkbox"/>	<input type="text"/>	<input type="checkbox"/>	<input type="checkbox"/>
RI32-	0 Standard	5 ... 1 500	A DC 5 V E DC 10 - 30 V ¹	R.11 Pilot, IP40, 6 mm * R.14 Pilot, IP40, 5 mm **	K push-pull ² short circuit proof D push-pull DC 5 V, ±30 mA	A Cable axial B Cable radial
<p>* flattened, see dimensional drawing ** not flattened ¹ only with output K ² ±10 mA at DC 5 V, ±30 mA at DC 10 - 30 V</p>						

Inkremental-Drehgeber RI 32

HENGSTLER

Hengstler GmbH
Postfach 11 51 Tel. 07424 – 890
D-78554 Aldingen Fax 07424 – 89370

Sach-Nr. 2 527 049

Ausgabe: 3 160604 Ste1

Vorwort

Diese Installationsanleitung soll Ihnen den Anschluß und die Inbetriebnahme des Drehgebers ermöglichen.

Weitere Informationen finden Sie im Drehgeberkatalog.

Sicherheits- und Betriebshinweise

- Die inkrementalen Drehgeber der Modellreihe RI 32 sind nach den anerkannten Regeln der Elektrotechnik hergestellte Qualitätsprodukte. Die Geräte haben das Herstellerwerk in sicherheitstechnisch einwandfreiem Zustand verlassen. Um diesen Zustand zu erhalten und um einen störungsfreien Betrieb sicherzustellen, sind die technischen Spezifikationen in dieser Dokumentation zu berücksichtigen.
- Einbau und Montage elektrischer Geräte dürfen nur durch eine Elektrofachkraft erfolgen!**
- Die Geräte dürfen nur innerhalb der Grenzwerte betrieben werden, wie sie in den technischen Daten vorgegeben sind.
- Die maximalen Betriebsspannungen dürfen nicht überschritten werden!** Die Geräte sind nach VDE 0160, Schutzklasse III gebaut. Sie müssen zur Verhinderung von gefährlichen Körperströmen mit Sicherheitskleinspannung (SELV) betrieben werden und sich in einem Bereich mit Potentialausgleich befinden.
- Vermeiden Sie die Einwirkung von Schocks auf das Gehäuse – vor allem auf die Geberwelle – sowie axiale und radiale Überlastungen der Geberwelle.
- Die maximale Genauigkeit und Lebensdauer der Geber wird nur bei Verwendung einer geeigneten Kupplung garantiert.
- Anwendungsbereich: industrielle Prozesse und Steuerungen. Überspannungen an den Anschlußklemmen müssen auf Werte der Überspannungskategorie II begrenzt werden.
- Die guten EMV-Werte gelten nur in Verbindung mit den serienmäßig gelieferten Kabeln und Steckern. Bei geschirmten Kabeln ist der Schirm beidseitig und großflächig mit Erde zu verbinden. Auch die Leitungen zur Spannungsversorgung sollten vollständig geschirmt sein. Ist dies nicht möglich, so sind entsprechende Filtermaßnahmen zu ergreifen.
- Die Einbaumgebung und Verkabelung hat maßgeblichen Einfluß auf die EMV des Gebers, so daß vom Installateur die EMV der gesamten Anlage (Gerät) sicherzustellen ist.
- Spannungsspitzen auf der Versorgungsleitung sind durch die vorgeschaltete Spannungsversorgung auf max. 1000 V zu beschränken.
- In elektrostatisch gefährdeten Bereichen ist bei der Installation auf einen guten ESD-Schutz für Stecker und anzuschließendes Kabel zu achten.

Anschlußbenennung der Kabel

Farbe	Ausgangsschaltung		
	RS 422 (T)	RS 422 (R)	Gegentakt (K, D)
weiß	Kanal A	Kanal A	Kanal A
weiß/braun	Kanal \bar{A}	Kanal \bar{A}	
grün	Kanal B	Kanal B	Kanal B
grün/braun	Kanal \bar{B}	Kanal \bar{B}	
gelb	Kanal N	Kanal N	Kanal N
gelb/braun	Kanal \bar{N}	Kanal \bar{N}	
gelb/schwarz	Sense GND	\bar{A} Alarm	\bar{A} Alarm
gelb/rot	Sense V_{cc}	Sense V_{cc}	
rot	5 V DC	5 V DC	5/10...30 V DC
schwarz	GND	GND	GND

Mechanische Daten

Befestigung	Rundflansch*
Wellendurchmesser	5 mm, 6 mm
Wellenbelastung	radial 10 N, axial 5 N
Drehzahl	6000 min ⁻¹
Drehmoment	≤ 0,05 Ncm
Schutzart Gehäuse/Kugellager	IP 50/40
Betriebstemperatur	-10 ... +60 °C
Lagertemperatur	-25 ... +85 °C
Schwingfestigkeit (IEC 68-2-6)	100 m/s ² (10 ... 2000 Hz)
Schockfestigkeit (IEC 68-2-27)	1000 m/s ² (6 ms)
Anschlußart	Kabel axial/radial
Material	Flansch: Aluminium, Kappe: Kunststoff
Masse	ca. 50 g

* Befestigung mit M3-Schrauben

Elektrische Daten

Allgemeine Auslegung	gemäß DIN VDE 0160, Schutzklasse III, Verschmutzungsgrad 2, Überspannungskategorie II			
Stromaufnahme	5V/40 mA, 24V/30 mA (10...30 V), 10V/60 mA (10...30V)			
Versorgungsspannung U_B	5 V DC (SELV) ±10%		10 ... 30 V DC (SELV)	
Ausgang ¹⁾	GT	GT	RS422	GT
Kennbuchstabe	K	D	R, T	K
Ausgangsbelastung [mA]	±10	±30	±30	±30
Ausgangspegel [V]	High Low	≥2,5 ≤0,5	≥2,5 ≤0,5	U_B -3 ≤2
Schaltzeiten [ns]	250	100	100	2000
max. Impulsfrequenz [kHz]	300	300	300	200
Verpolschutz	ja	nein	nein	ja
Kurzschlußfestigkeit	ja	1 Kanal	1 Kanal	ja
Tastverhältnis	1 : 1			
Toleranz	± 25° elektrisch			
Phasenversatz	90° (zwischen Kanal A und B min. 0,45 µs, bei 300 kHz)			
Impulsform	Rechteck			
Alarm-Ausgang	offener Kollektor, NPN (bei $U_B=5$ VDC: max. 5 mA, 24 V; bei $U_B=10...30$ VDC: max. 5 mA, 32 V)			

¹⁾ GT=Gegentakt; RS422=Line driver

Bestellschlüssel (siehe Typenschild)

0 Standard	Versorgungsspannung A 5 VDC E 10 ... 30 VDC	Flanschart R Rundflansch	Wellen- durchmesser 1 6 mm 4 5 mm
Strichzahl 5 ... 1500	Schutzart 1 IP 40	Ausgang K Gegentakt kurzschlußfest D Gegentakt 5V, ± 30 mA R RS 422 + Alarm T RS 422 + Sense	Anschlußart A Kabel axial B Kabel radial

* Sonderausführungen sind im Bestellschlüssel zusätzlich mit -S gekennzeichnet. In diesem Fall gelten kundenspezifische Daten. Sollten Ihnen diese nicht bekannt sein, so fordern Sie die Daten bitte unter Angabe der Geber-Sachnummer bei uns an.

Incremental Shaft Encoders Type RI 32

Item No. 2 527 049

Edition: 3 160604 Ste1

HENGSTLER

Hengstler GmbH
Postfach 11 51 Tel. 07424 – 890
D-78554 Aldingen Fax 07424 – 89370

Introduction

These installation instructions are provided for the connection and starting procedure of your shaft encoder.

For further informations see our Shaft Encoders Catalogue.

Safety and Operating Instructions

- The incremental shaft encoders of the type RI 32 model series are quality products manufactured in accordance with established electrical engineering standards.
The units have been delivered from the factory in perfect conformance to safety regulations.
To maintain this condition and to ensure trouble-free operation, please observe the technical specifications of this document.
- Installation and mounting may only be performed by an electrotechnical expert!**
- The units may only be operated within the limits specified by the technical data.
- Maximum operating voltages must not be exceeded!**
The units are designed complying with VDE 0160, protection class III.
To prevent dangerous structure-borne currents, the equipment has to be run on safety extra-low voltage (SELV) and must be in an area of equipotential bonding.
- Please avoid shocks to the housing – especially to the encoder shaft – and axial or radial overload to the encoder shaft.
- Maximum accuracy and durability of our shaft encoders is only granted when using suitable couplings.
- Application: Industrial processes and control systems.
Overvoltage at the connecting terminals must be limited to the values within overvoltage category II.
- The high-quality EMC-specifications are only valid together with standard-type cables and plugs. When using screened cables the screen must broadly be connected with ground on both ends. Likewise, the voltage-supply cables should entirely be screened. If this is not possible you will have to take appropriate filtering measures.
- Installation environment and wiring are influential on the encoder's EMC: Thus the installer must secure EMC of the whole facility (device).
- Transient peaks on the power supply leads are to be limited by the pre-connected power unit to a maximum of 1000 V.
- In electrostatically threatened areas please take care for neat ESD-protection of plug and connecting cable during installation work.
- For use in class II circuits only

Connection diagram

Colour	Output RS 422 (T)	RS 422 (R)	Push-pull (K, D)
white	Channel A	Channel A	Channel A
white/brown	Channel \bar{A}	Channel \bar{A}	
green	Channel B	Channel B	Channel B
green/brown	Channel \bar{B}	Channel \bar{B}	
yellow	Channel N	Channel N	Channel N
yellow/brown	Channel \bar{N}	Channel \bar{N}	
yellow/black	Sense GND	Alarm	$\bar{A}larm$
yellow/red	Sense V_{cc}	Sense V_{cc}	
red	5 V DC	5 V DC	5/10...30 V DC
black	GND	GND	GND

Mechanical data

Mounting	round flange*
Shaft diameter	5 mm, 6 mm
Absolute max shaft load	radial 30 N (6.5 lbs), axial 15 N (3.3 lbs)
Maximum speed	6,000 RPM
Torque	≤ 0,05 Ncm
Protection class	
housing/ball bearing	IP 50/40
Operating temperature	-10 ... +60 °C
Storage temperature	-25 ... +85 °C
Vibration performance (IEC 68-2-6)	100 m/s ² (10 ... 2000 Hz)
Shock resistance (IEC 68-2-27)	1000 m/s ² (6 ms)
Connection	cable axial/radial
Material	flange: aluminium, cover: plastics
Weight	50 g approx.
Bearing life	2.4 x 10 ⁹ revolutions at 35% of full rated shaft load 2.4 x 10 ⁹ revolutions at 75% of full rated shaft load 2.4 x 10 ⁷ revolutions at 100% of full rated shaft load e.g. 10,000 h at 4,000 RPM with a 2 lb radial load

* use threads M3 for fastening

Electrical data

General design	as per DIN VDE 0160, protection class III, contamination level 2, overvoltage class II			
Power consumption	5V/40 mA, 24V/30 mA (10...30 V), 10V/60 mA (10...30V)			
Supply voltage U_B (SELV)	5 V DC ±10%			10...30 VDC
Output circuit ¹⁾	PP	PP	RS422	PP
Code letter	K	D	R, T	K
Output load [mA]	±10	±30	±30	±30
Output voltage [V]	High	≥2.5	≥2.5	≥2.5
	Low	≤0.5	≤0.5	≤0.5
Pulse rise time [ns]	250	100	100	2000
Max. pulse frequency [kHz]	300	300	300	200
Reverse polarity protection	yes	no	no	yes
Short-circuit protection	yes	1 channel	1 channel	yes
Pulse duty factor	1 : 1			
Pulse width error	± 25° electrical			
Phase shift	90° (distance from Channel A to B is at least 0.45 µs, at 300 kHz)			
Pulse shape	rectangular			
Alarm output	Open Collector, NPN (with $U_B=5$ VDC: max. 5 mA, 24 V; with $U_B=10...30$ VDC: max. 5 mA, 32 V)			

¹⁾ PP=Push-pull; RS422=Line driver

Ordering data (see identification plate)

0 Standard	Supply voltage A 5 VDC E 10 ... 30 VDC	Type of flange R Round flange	Shaft diameter 1 6 mm 4 5 mm
Number of pulses 5 ... 1,500	Protection class 1 IP 40	Output K Push-pull short circuit proof D Push-pull 5V, ±30 mA R RS 422 + Alarm T RS 422 + Sense	Type of connection A Cable axial B Cable radial

* Special types are additionally marked by an ordering code -S. In this case customer specifications are to be applied. If you don't know these please call us for the specifications, indicating the encoder ordering code.